

Searching PAJ

Page 1 of 2

**PATENT ABSTRACTS OF JAPAN**

(11)Publication number : 11-149107

(43)Date of publication of application : 02.06.1999

---

(51)Int.Cl. G03B 15/00  
G03B 17/02  
H04N 5/225

---

(21)Application number : 09-314994 (71)Applicant : CANON INC  
(22)Date of filing : 17.11.1997 (72)Inventor : KAWASHIMA SHOSAKU

---

**(54) ELECTRON CAMERA****(57)Abstract:**

**PROBLEM TO BE SOLVED:** To freely change a photographing direction without forming a separate unit.

**SOLUTION:** The main body 50 is provided with an image pickup element 52, a photographic lens 54 for forming an optical image on the image pickup element 52 and a liquid crystal display panel 55 for displaying a photographed image and a reproduced image, all of which are installed in a fixed state. A prism 56 or a reflection mirror with a reflection surface which is at an angle of 45° to the optical axis of the photographic lens 54 and for turning the photographic optical axis by 90° is arranged ahead of the photographic lens 54. The prism 56 is mounted to the main body 50 so as to be freely rotated around the optical axis of the photographic lens 54. The prism 56 is rotated by a prism rotating knob 58 with reference to the main body 50, thus, the photographing direction is continuously changed at an angle  $\geq$  almost 180° in a plane vertical to the optical axis of the photographic lens 54.

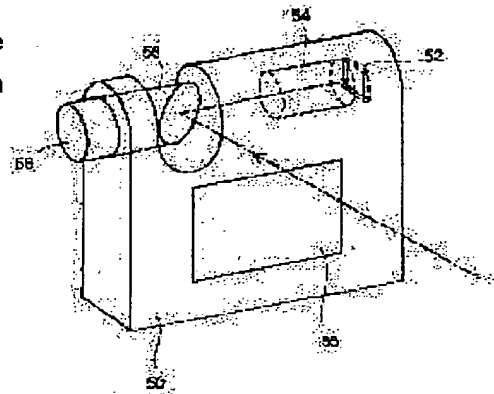
**LEGAL STATUS**

[Date of request for examination]

<http://www19.ipdl.ncipi.go.jp/PA1/result/detail/main/wAAA7EaGWhDA411149107P1.htm> 2/7/2007

Searching PAJ

Page 2 of 2

[Date of sending the examiner's decision of rejection]

[Kind of final disposal of application other than the examiner's decision of rejection or application converted registration]

[Date of final disposal for application]

[Patent number]

[Date of registration]

[Number of appeal against examiner's decision of rejection]

[Date of requesting appeal against examiner's decision of rejection]

[Date of extinction of right]

18-299Reference2

\* NOTICES \*

JPO and NCIP1 are not responsible for any damages caused by the use of this translation.

1. This document has been translated by computer. So the translation may not reflect the original precisely.
2. \*\*\*\* shows the word which can not be translated.
3. In the drawings, any words are not translated.

CLAIMS [Claim(s)]

[Claim 1] The electronic camera comprising an image pick-up means to change an optical image into an electrical signal, and a photography optical system which carries out image formation of the optical image to the image pick-up means concerned, wherein the photography optical system comprises a shooting-direction modification means which turns shooting-direction towards desired.

[Claim 2] The electronic camera according to claim 1 which is the optical means whose modification of bearing of the exposure axis the bearing-of-the-exposure-axis modification optical means concerned enables in a field perpendicular to the incident light shaft of the image pick-up means concerned.

[Claim 3] The electronic camera according to claim 1, wherein the shooting-direction modification means is the optical means which enables in a field including the incident light shaft of the image pick-up means concerned.

[Claim 4] Furthermore, the electronic camera possessing a detection means to detect the bearing of the exposure axis by the bearing-of-the-exposure-axis modification optical means concerned, and an image conversion means to change the photography image by the image pick-up means concerned in the predetermined direction of an image according to the detection result of the detection means concerned according to claim 1.

18-299Reference2

## DETAILED DESCRIPTION [Detailed Description of the Invention]

[0001]

[Field of the Invention] More specifically, this invention relates to the electronic camera which can choose bearing of the exposure axis free about an electronic camera.

[0002]

[Description of the Prior Art] The conventional electronic camera can be divided roughly into the type with which bearing of the exposure axis is being fixed to the body, and the type which can change bearing of the exposure axis to a body. Many of latter types have composition which enables relatively rotation of the camera section which has photography optical system and an image sensor (it is a camera digital disposal circuit to a list) to the display which has a monitor display. Since the camera section is equipped also with a display being equipped with the record regeneration system which carries out record regeneration of the record medium of a photography image, and the photography image, further, a display may be equipped with the part and the camera section may be equipped with the remainder.

[0003] The perspective view of an example of the conventional example to which rotation of the camera section is attained to the display is shown in Fig. 7. The body with which 10 possesses the liquid crystal display monitor display 12 (and record regeneration system which carries out record regeneration of the record medium of a photography image and the photography image), and 14 It is the camera unit which has a taking lens 16 (they are an image sensor and a camera digital disposal circuit to a list). The camera unit 14 To a body 10, as shown in Fig. 8, it is supported free [ rotation ] in the horizontal plane, and can change now into the predetermined angular position (or free angular position), for example, 90 degrees.

[0004] Fig. 9 shows the circuit block diagram of the conventional example shown in Fig. 7 and Fig. 8. A body 10 possesses the display-control circuit 18 which controls the liquid crystal display monitor display 12, the control circuit 20 of a body which controls the whole, and the sensor 22 which detects the direction of the camera unit 14. The camera unit 14 possesses the camera digital disposal circuit 26 which carries out camera signal processing of the output signal of an image sensor 24 and an image sensor 24 other than a taking lens 16. The control circuit 20 of a body and the camera digital disposal circuit 26 are electrically connected through the signal line of the number of fixed number of line.

[0005] Fig. 10 shows the perspective view of the conventional example which carried out hinge association of the display unit 34 which has a monitor display to the body 30 while equipping a body 30 with a taking lens 32, an image sensor, and a camera signal-

18-299Reference2

processing system. Fig. 11 shows the perspective view in the condition of having started the display unit 34 to the body 30. In the condition of having become observation from the camera tooth back and having stood where the monitor display 36 is folded up in this conventional example, it becomes observation from the front face of a camera.

[0006] Fig. 12 shows the circuit block diagram of the conventional example shown in Fig. 10 and Fig. 11. A body 30 possesses the sensor 44 which detects whether the image sensor 38, the camera digital disposal circuit 40, the control circuit 42 of a body, and the display unit 34 other than a taking lens 32 are folded, or it is stood, and the display unit 34 possesses the display-control circuit 46 which controls the liquid crystal display monitor display 36. The control circuit 42 of a body and the display-control circuit 46 are electrically connected through the signal line of the number of fixeds number of line.

[0007]

[Problem(s) to be Solved by the Invention] Two independent units are needed and it is hard coming to plan a miniaturization in the conventional example in the configuration which, other than this, connects for example, a display unit with a camera unit free [ rotation ] mutually. Namely, in order to equip an electronic circuitry for every independent unit. It is because it can collect neither into one electronic-circuitry substrate nor the semiconductor chip of 1 or a fraction.

[0008] Furthermore, since between two units will be connected with a signal cable etc., it is easy to produce a problem in respect of dependability or reinforcement.

[0009] This invention aims at showing the electronic camera which solved such a trouble.

[0010] This invention aims at showing the electronic camera which can change bearing of the exposure axis freely in an independent unit again.

[0011]

[Means for Solving the Problem] It is characterized by the electronic camera concerning this invention possessing bearing-of-the-exposure-axis modification \*\*\*\*\*

possessing an image pick-up means to change an optical image into an electrical signal, and the photography optical system which carries out image formation of the optical image to the image pick-up means concerned by which it is an electronic camera and the photography optical system concerned turns bearing of the exposure axis towards desired.

[0012] Thereby, bearing of the exposure axis can be changed, without separating an internal circuitry for every unit. Therefore, an internal circuitry is summarized to one electronic-circuitry substrate, or it becomes possible to summarize two or more functions to one semiconductor chip, and miniaturization and low-pricing can be

18-299Reference2

realized. Furthermore, since the need of connecting two or more units with a signal cable etc. by flight readiness is lost, dependability and reinforcement can be raised.

[0013] A bearing-of-the-exposure-axis modification optical means is the optical means whose modification of bearing of the exposure axis is enabled in a field perpendicular to the incident light shaft of for example, an image pick-up means, or an optical means whose modification of bearing of the exposure axis is enabled in a field including the incident light shaft of an image pick-up means.

[0014] Even if it changes bearing of the exposure axis by establishing a detection means to detect the bearing of the exposure axis by the bearing-of-the-exposure-axis modification optical means, an image conversion means to change the photography image by the image pick-up means in the predetermined direction of an image according to the detection result of the detection means concerned, and a conversion means to amend distortion of a photography image, the image with which the person image always stood erect, for example can be obtained.

[0015]

[Embodiment of the Invention] Hereafter, the gestalt of operation of this invention is explained to a detail with reference to a drawing.

[0016] Fig. 1 shows the perspective view of one example of this invention. In order to make an understanding easy, a part is seen through and it has illustrated. The body 50 is equipped with the liquid crystal display panel 55 which displays a photography image and a playback image on the taking-lens 54 list which carries out image formation of the optical image to an image sensor 52 and an image sensor 52 fixed. Ahead [ of a taking lens 54 ], the reflector of 45 degrees is provided to the optical axis of a taking lens 54, and the prism 56 or reflective mirror which converts a photography optical axis 90 degrees is arranged in it. The body 50 is equipped with prism 56 free [rotation] centering on the optical axis of a taking lens 54. Prism 56 can be rotated to a body 50 by the prism rotatable knob 58, and, thereby, can change bearing of the exposure axis continuously over about 180 degrees or more in a field perpendicular to the optical axis of a taking lens 54.

[0017] Fig. 2 shows the outline configuration block Fig. of the internal circuitry of the example shown in Fig. 1. The optical image of the photographic subject of the bearing of the exposure axis decided by the prism 56 which rotates by the prism rotatable knob 58 carries out image formation to an image sensor 52 with prism 56 and a taking lens 54, is changed into an electrical signal, and is impressed to the camera digital disposal circuit 60. The camera digital disposal circuit 60 performs well-known camera signal processing (gain control, gamma amendment, color balance adjustment, etc.) to the

18-299Reference2

output signal of an image sensor 52, and impresses it to the control circuit 62 of a body. The include angle of prism 56, i.e., the output of the sensor 64 which detects bearing of the exposure axis, is supplied to the control circuit 62 of a body, and image amendment processing of rotation, reversal, refraction, etc. is performed to the output picture signal of the camera digital disposal circuit 60 if needed according to the bearing-of-the-exposure-axis information from the sensor 64. Image display of the picture signal to which image amendment processing was performed is carried out by the display-control circuit 66 on the screen of the liquid crystal display panel 55. The picture signal to which image amendment processing was performed is recorded on the record medium which is not illustrated according to a user's predetermined shutter operation again.

[0018] Fig. 3 shows the perspective view of the 2nd example of this invention. A part is seen through like Fig. 1 and it has illustrated. The same sign is given to the same component as Fig. 1. The dioptric system 68 which unified these functions was formed in body 50a of the example shown in Fig. 3 instead of the taking lens 54 in the example shown in Fig. 1, and prism 56. That is, the object side of dioptric system 68 is aslant omitted to the optical axis so that the same function as prism 56 may be achieved substantially.

[0019] Fig. 4 shows the outline configuration block Fig. of the internal circuitry of the example shown in Fig. 3. The same sign is given to the same component as Fig. 2. Since the actuation of the circuit shown in Fig. 4 itself is completely the same as the circuit shown in Fig. 2, explanation is omitted.

[0020] Fig. 5 shows the perspective view of the 3rd example of this invention. A part is seen through like Fig. 1 and Fig. 3, and it has illustrated. The same sign is given to the same component as Fig. 1. In the example shown in Fig. 1 and Fig. 3, even if prism 56 or dioptric system 68 was which location, the optical axis of a taking lens 54 and the optical axis inside dioptric system 68 enabled modification of the include angle in which the optical axis of bearing of the exposure axis and a taking lens 54 succeeds in the example indicated to be bearing of the exposure axis to Fig. 5 although it was right-angled. That is, the movable mirror 70 whose modification is enabled in the desired include-angle range in the fixed side (usually horizontal plane) which includes this optical axis for the optical axis of a taking lens 54 ahead of a taking lens 54 is arranged, and the user enabled it to change the include angle of the movable mirror 70 free by the control lever 72 in body 50b of the example shown in Fig. 5.

[0021] Fig. 6 shows the outline configuration block Fig. of the internal circuitry of the example shown in Fig. 4. The same sign is given to the same component as Fig. 2. Since the actuation of the circuit shown in Fig. 6 itself is completely the same as the circuit

18-299Reference2

shown in Fig. 2 , explanation is omitted.

[0022] The usage which changes the conventional camera-usage photographed while what faced the photographic subject to photo squarely as an example which chooses the bearing of the exposure axis of arbitration is compared with the thing displayed on the display, and the TV phone-usage which photos itself in an instant can be considered. In addition, a means to change bearing of the exposure axis may be motorised [ not only by the example of illustration but the micro motor ].

[0023] Moreover, the configuration of this invention is applicable not only to a mere portable electronic device with an electronic camera but for example, a digital video camera and a portable terminal unit for television conferences.

[0024] Moreover, this invention is applicable to for example, a medical-application endoscope, an industrial use endoscope, or the surveillance camera of remote operation by using small optical system.

[0025] According to this invention, since a body appearance configuration does not change with modification of bearing of the exposure axis, it is very effective to change bearing of the exposure axis widely in a narrow location.

[0026]

[Effect of the Invention] Since it becomes possible to change bearing of the exposure axis, without changing the configuration of an appearance according to this invention so that he can understand easily from the above explanation, it becomes possible [ it becoming unnecessary to use a camera unit as another object therefore, and summarizing various electronic circuitries to the electronic-circuitry substrate of one sheet, or one semiconductor chip ], or easy. Consequently, a miniaturization and low-pricing are realizable.

[0027] furthermore, two or more units -- a signal cable -- connecting -- in addition -- and since it becomes unnecessary to take the complicated configuration of making both units into material relatively at the time of migration, dependability and reinforcement improve by leaps and bounds.

[Brief Description of the Drawings]

[Fig. 1] It is the perspective view of the 1st example of this invention.

[Fig. 2] It is the outline configuration block Fig. of the internal circuitry of the example shown in Fig. 1 .

[Fig. 3] It is the perspective view of the 2nd example of this invention.

[Fig. 4] It is the outline configuration block Fig. of the internal circuitry of the example shown in Fig. 3 .

[Fig. 5] It is the perspective view of the 3rd example of this invention.



18-299Reference2

[Fig. 6] It is the outline configuration block Fig. of real child Ric's internal circuitry shown in Fig. 5 .

[Fig. 7] It is the perspective view of the conventional example.

[Fig. 8] It is a perspective view in the condition of having rotated the camera unit 14 in the conventional example shown in Fig. 7 .

[Fig. 9] It is the outline configuration block Fig. of the internal circuitry of the conventional example shown in Fig. 7 and Fig. 8.

[Fig. 10] It is the perspective view of another conventional example.

[Fig. 11] It is a perspective view in the condition of having started the display unit 34 in the conventional example shown in Fig. 10 .

[Fig. 12] It is the outline configuration block Fig. of the internal circuitry of the conventional example shown in Fig. 10 and Fig. 11 .

[Description of Notations]

10: Body

12: Liquid crystal display monitor display

14: Camera unit

16: Taking lens

18: Display-control circuit

20: The control circuit of a body

22: Sensor

24: Image sensor

26: Camera digital disposal circuit

30: Body

32: Taking lens

34: Display unit

36: Monitor display

38: Image sensor

40: Camera digital disposal circuit

42: The control circuit of a body

44: Sensor

46: Display-control circuit

50, 50a, 50b: Body

52: Image sensor

54: Taking lens

55: Liquid crystal display panel

56: Prism

18-299Reference2

- 58: Prism rotatable knob
- 60: Camera digital disposal circuit
- 62: The control circuit of a body
- 64: Sensor
- 66: Display-control circuit
- 68: Dioptic system
- 70: Movable mirror
- 72: Control lever

[Translation done.]

**This Page is Inserted by IFW Indexing and Scanning  
Operations and is not part of the Official Record**

**BEST AVAILABLE IMAGES**

Defective images within this document are accurate representations of the original documents submitted by the applicant.

Defects in the images include but are not limited to the items checked:

- BLACK BORDERS
- IMAGE CUT OFF AT TOP, BOTTOM OR SIDES
- FADED TEXT OR DRAWING
- BLURRED OR ILLEGIBLE TEXT OR DRAWING
- SKEWED/SLANTED IMAGES
- COLOR OR BLACK AND WHITE PHOTOGRAPHS
- GRAY SCALE DOCUMENTS
- LINES OR MARKS ON ORIGINAL DOCUMENT
- REFERENCE(S) OR EXHIBIT(S) SUBMITTED ARE POOR QUALITY
- OTHER: \_\_\_\_\_

**IMAGES ARE BEST AVAILABLE COPY.**

**As rescanning these documents will not correct the image problems checked, please do not report these problems to the IFW Image Problem Mailbox.**